

REV	DATE	ECN #	COMMENT
A	2017-02-02		INITIAL RELEASE
B	2017-05-15		UPDATED J6, R37-R39, ADDED J9, J10, R46-R50
C	2017-08-16		UPDATED C4 (DNP), C5 (1uF), R4 (33K), R5 (10K)
D	2017-11-08		UPDATE LED1 & LED2 TO EVERLIGHT

### Accelerometer

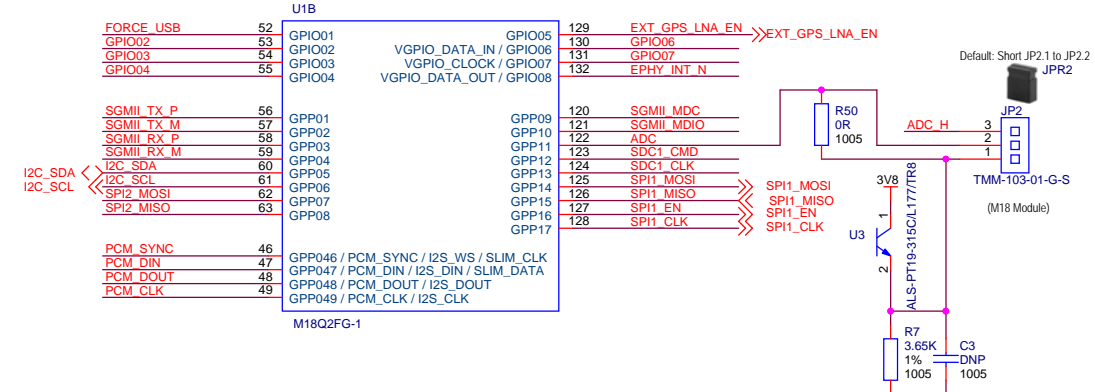

### Expansion Connector

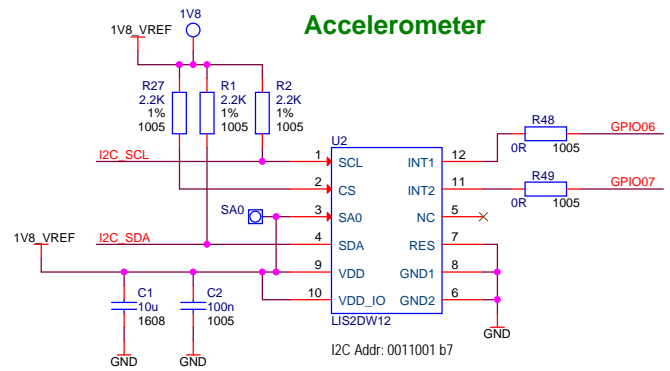
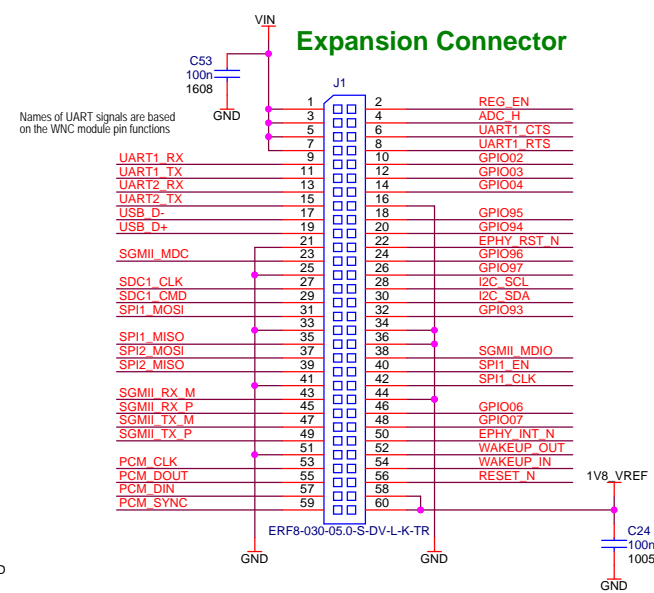

### USB Boot Switch

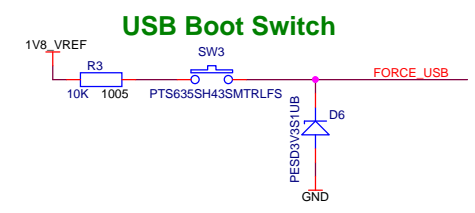

### User Switch

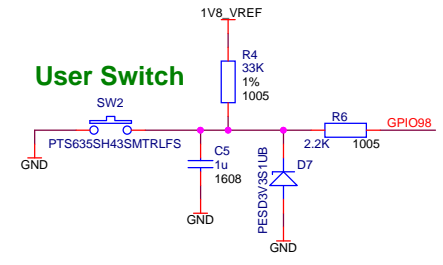

### Reset Switch

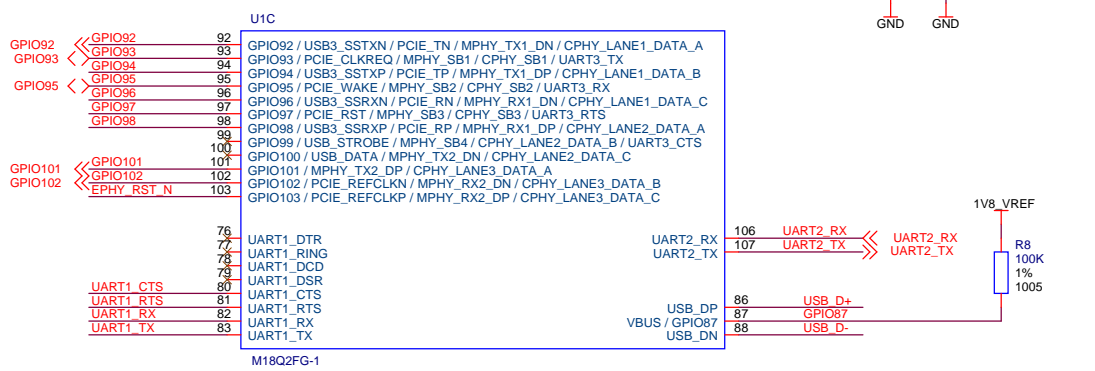
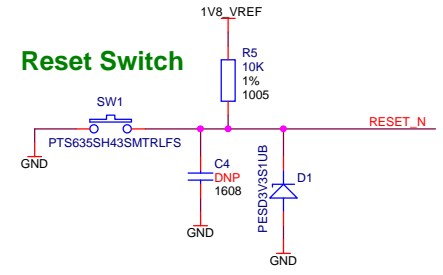

### Micro SIM-Card

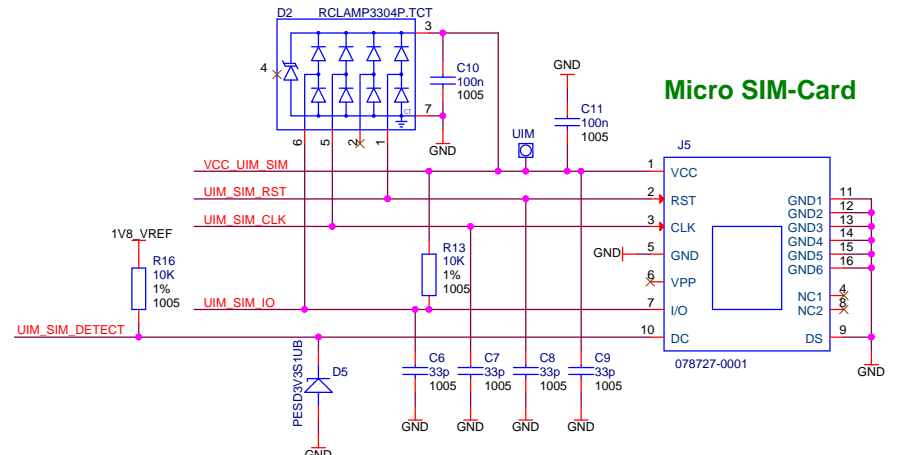

### USB

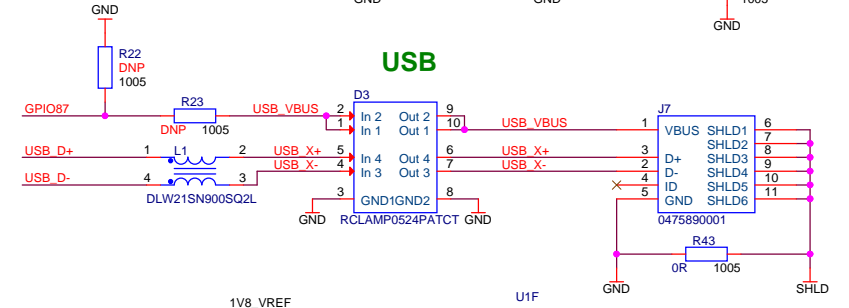

### 3V8 Power Supply

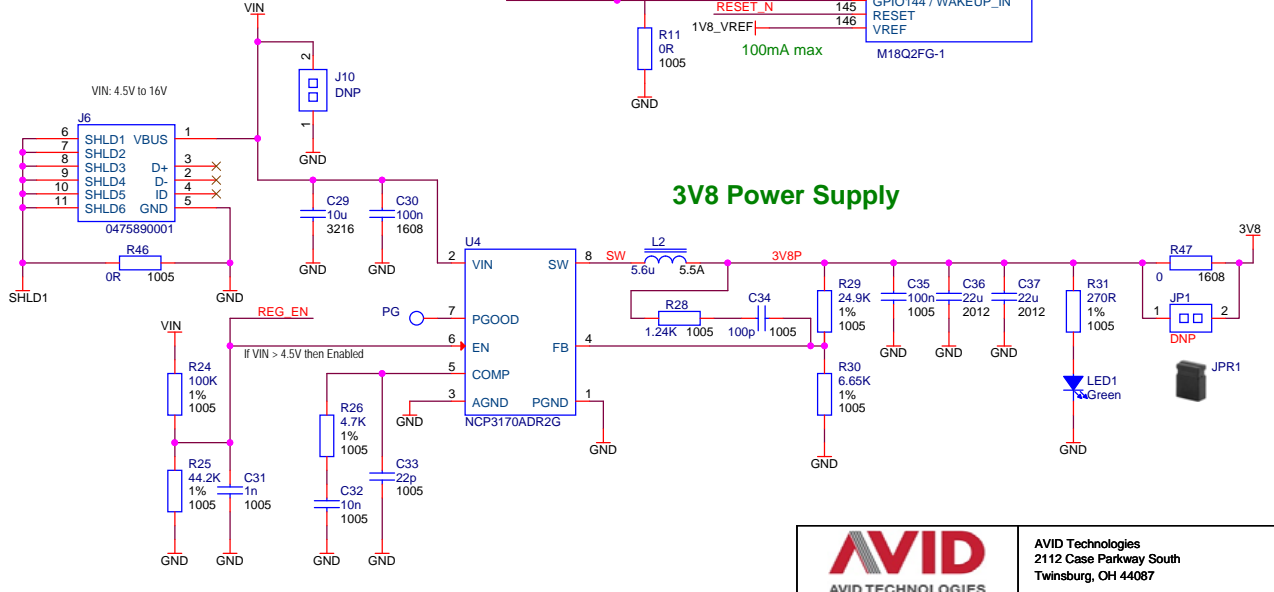

PCB: ATT-M18Qxx-M1-PCB-B

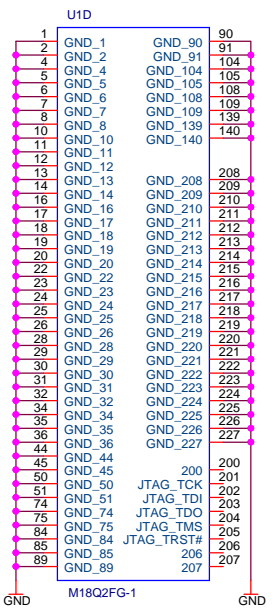
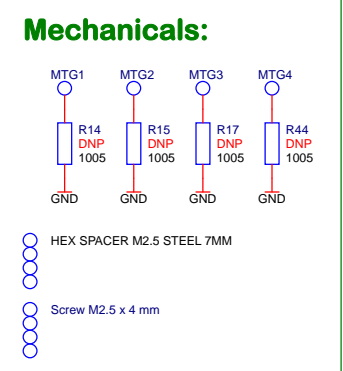
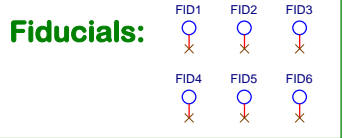

**AVID**  
 AVID TECHNOLOGIES  
 An Amnet Company

AVID Technologies  
 2112 Case Parkway South  
 Twinsburg, OH 44087  
 Copyright © AVID Technologies

**AT&T North America IoT LTE Module**

Release Number	Document Number	Rev
	ATT-M18Q2FG-M1-G_SCH	D

Size: C Date: Wednesday, November 08, 2017 Sheet 1 of 2

## GNSS/GPS

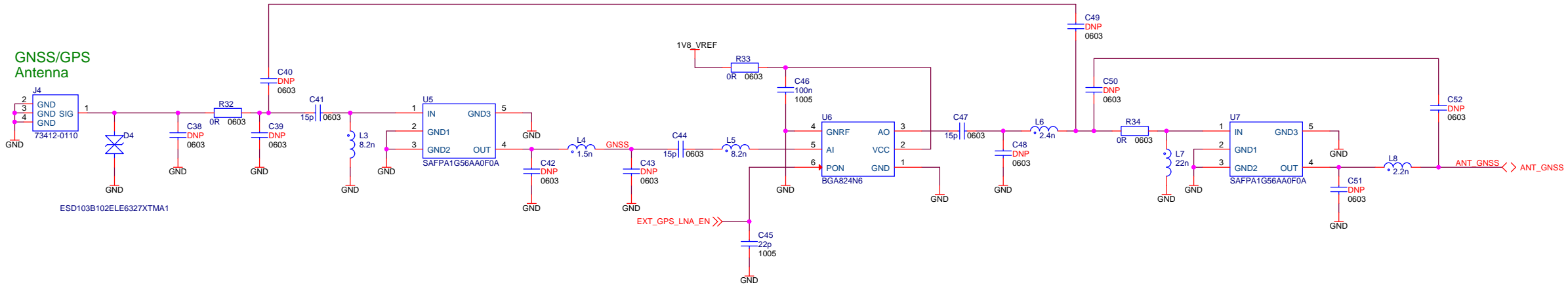

## Antennas

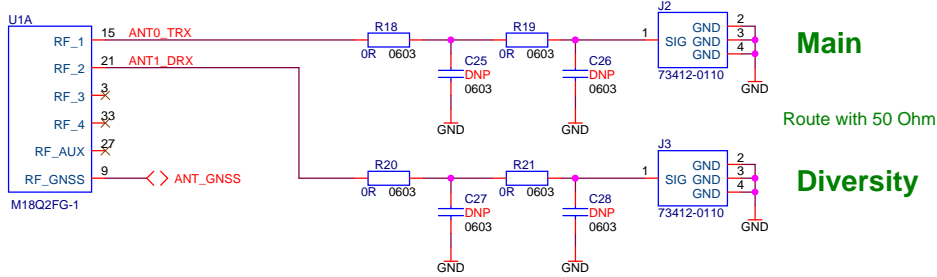

## RGB LED

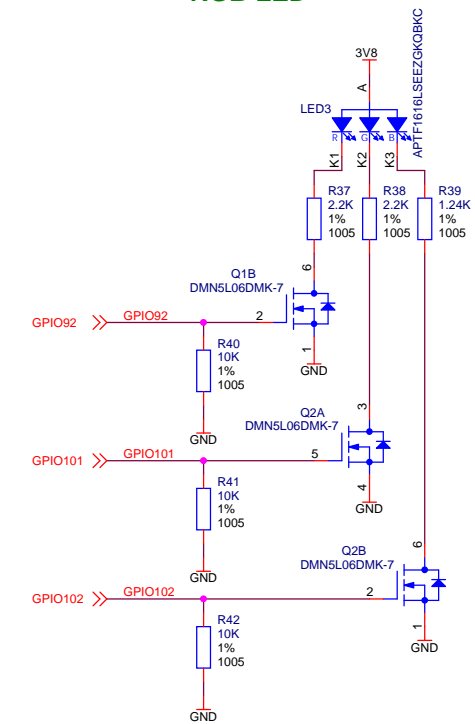

## 1V8 to 3V3 Level Translator

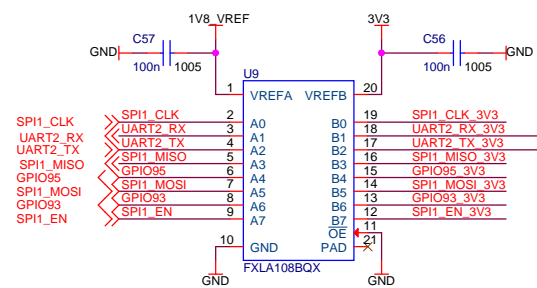

## UART

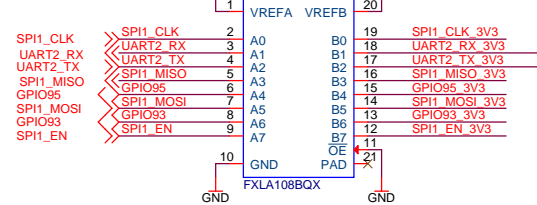

## Pmod I2C / SPI Interface

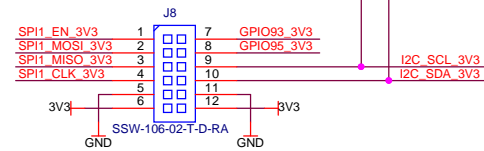

## Wireless WAN LED

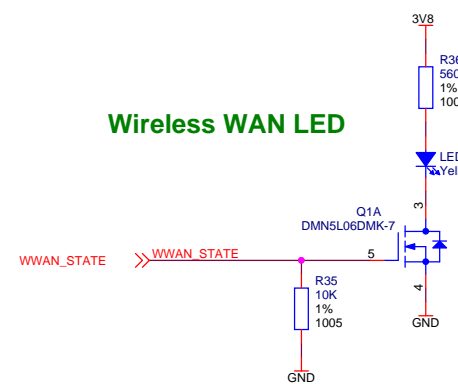

## 3V3 LDO

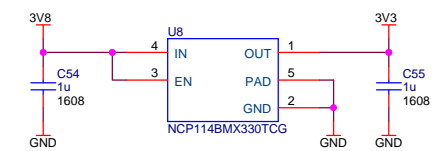

		AVID Technologies 2112 Case Parkway South Twinsburg, OH 44087
<b>AT&amp;T North America IoT LTE Module</b>		
Release Number	Document Number	Rev
	ATT-M18Q2FG-M1-G_SCH	D
Size: C	Date: Wednesday, November 08, 2017	Sheet 2 of 2