

AT&T Cellular IoT Starter Kit

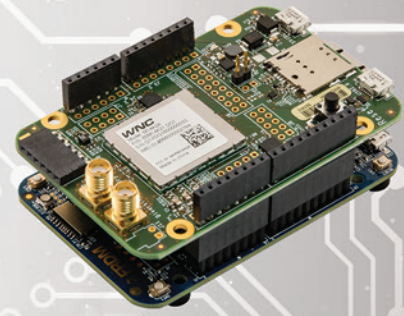

Electronics Marketing



Technology



DESIGNED BY AVNET

Kit Includes:

- NXP K64F Freedom Board
- Avnet M14A2A Cellular Shield
- AT&T IoT SIM Starter Pack
- Two Pulse LTE Stealth Blade Antennas
- Two micro-USB Cables
- 5V AC/DC USB Power Supply
- Quick Start Card
- Downloadable Tutorials and Documentation

Target Apps:

- Mobile IoT
- Building Automation
- Factory Automation
- Smart Agriculture
- Cellular/Mesh Network Bridging

Avnet's AT&T Cellular IoT Starter Kit enables designers to easily develop and prototype cellular connected IoT devices utilizing AT&T's 4G LTE network. The kit includes all the elements required to collect sensor data, connect to the AT&T network, and utilize various cloud services for the management, storage, and analytics of a connected IoT device.

The Starter Kit features a two board solution comprised of a microcontroller-based carrier board and a pluggable, cellular connectivity daughter card. NXP's Freedom FRDM-K64F microcontroller carrier board acts as the main host processor, providing an Arduino™ compatible R3 expansion slot. The Avnet created 4G LTE cellular shield plugs into the Arduino R3 slot, forming a small 3.25" x 2" x 1" two board "sandwich". The FRDM-K64F board contains a Kinetis K64F microcontroller, based on an ARM® Cortex®-M4 MCU running at 120 MHz, with 1MB Flash memory, 256 KB RAM, Ethernet port, USB port, microSD card slot, and a 6-axis digital accelerometer and magnetometer. The 4G LTE cellular shield is built around the low-cost Wistron NeWeb Corp. (WNC) M14A2A LTE Cat-1 modem module. The shield supports primary and diversity external antenna connections through two onboard SMA connectors, a 3FF microSIM connector, a temperature and humidity sensor, and multiple serial link options to the host controller.

Application development is supported by AT&T's M2X Data Services and Flow Designer, which provides a scalable, reliable and highly secure environment for IoT-focused solutions. Additional cloud services from industry partners are also available. The hardware platform is enabled for ARM® mbed™, allowing for development in a cloud-based environment, or in a locally supported environment through either the Open Source SDA or JTAG connection to the baseboard.

Feature List

NXP K64F Freedom Board

- MK64FN1MOVLL12 MCU
 - 120 MHz
 - 1 MB Flash memory
 - 256 KB RAM
 - Low-power, crystal-less USB
- Dual role USB interface with micro-B USB connector
- RGB LED
- FXOS8700CQ accelerometer and magnetometer
- Two user push buttons
- Ethernet
- Micro-SD card slot

Avnet M14A2A Cellular Shield

- LTE Cat-1 modem (WNC M14A2A)
- 3FF microSIM socket
- USB 2.0
- Arduino shield connectors
- Primary and diversity antenna connections
- Pmod x1
- Temp/Humidity sensor

AT&T IoT SIM Starter Pack

- 300 MB Data
- 300 SMS messages
- Valid for up to 6 months
- Domestic AT&T US and AT&T Mexico (no roaming)

Pulse LTE Stealth Blade Antenna

- Dipole antenna
- Supports LTE Bands 2, 4, and 12

Block Diagram

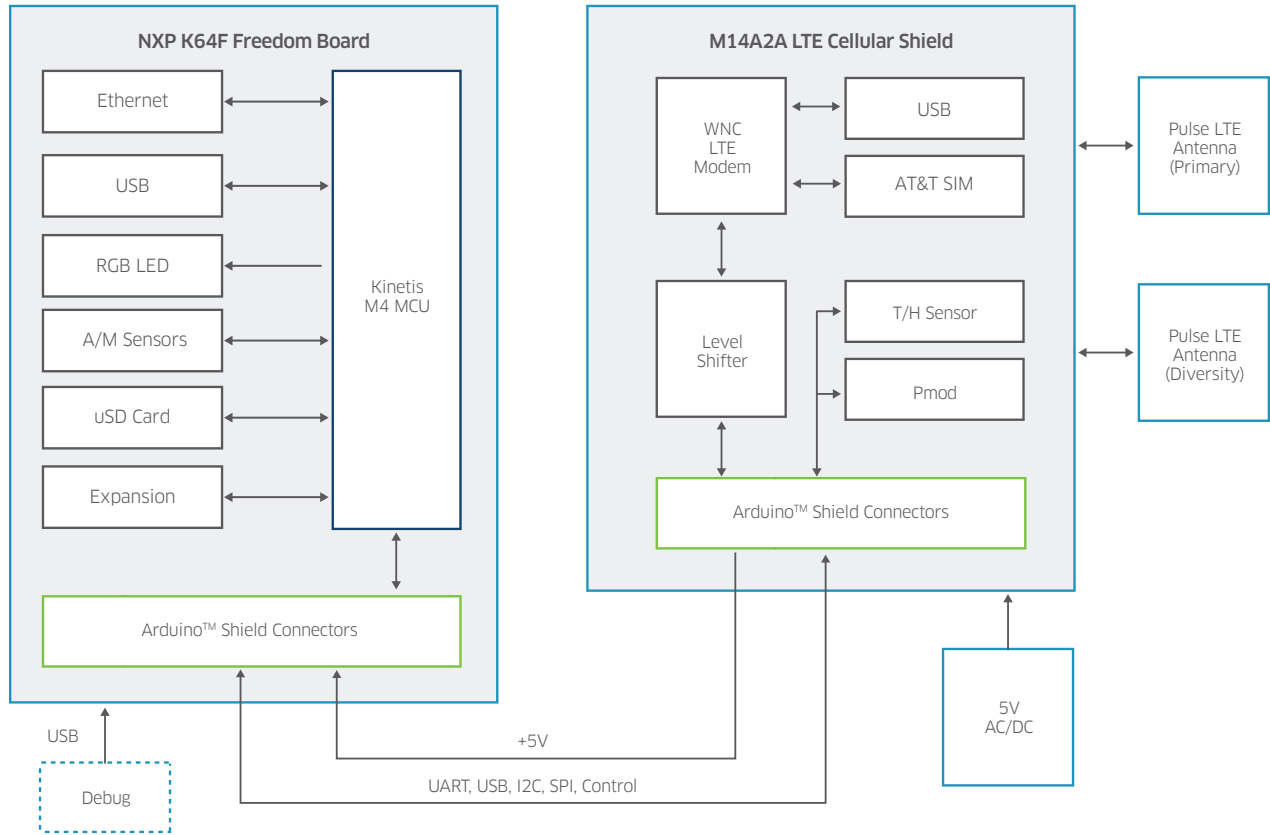

Featured Manufacturers



Parts:

Part Number	Description	Resale
AES-ATT-M14A2A-IOT-SK-G	AT&T Cellular IoT Starter Kit	\$99.00

Related Parts:

Part Number	Description	Resale
SB698SMA3	Pulse LTE Blade Antenna	\$20.00

Countries Available for Purchase: Americas